



# Dynaco ST-70 & Mark 2/3 Quad-Cap / Power Supply Module Below Chassis Version Assembly, Installation & Setup Manual

Page 1

CAE QUAD Cap Replacement Module PC-S7U-B & PC-S7U-B-M3 Rev3, 2-11

## I. Introduction

Thank you for choosing our ST-70 & Mark 2/3 Quad Electrolytic Capacitor & Power Supply Replacement Board. It is developed and designed to replace the original Dynaco quad electrolytic capacitor and the major bias supply components for both the Dynaco Stereo-70 amplifier (ASM-S7U-B) and the Dynaco Mark 2/3 amplifiers (ASM-S7U-B-M3). Essentially, it replaces the entire power supply in Dynaco power amplifiers (but for the transformer and rectifier) .

The original Dynaco quad capacitor has always been the weakest link in the original Dynaco design due to its high ESR (series resistance) and marginal voltage ratings (especially when challenged with 21<sup>st</sup> century AC line voltages). The high ESR results in high internal temperatures that severely compromise the amps reliability. These problems persist even with both NOS and new production “quad” capacitors designs as the high ESR is due to the physical design of the capacitors.

Besides reliability issues there are audible problems with the original capacitor caused by a rising impedance characteristic that is well within the audio spectrum resulting in loose bass response and dull high frequencies.

The CAE S7U-B (M3) replacement PC boards solve all of these problems with the use of a high quality capacitor bank that not only increases the voltage rating (to 600VDC from 525V) but also increases the total capacitance (and therefore energy storage). The ESR drops from several ohms to milliohms. Most important to audiophiles, our capacitors exhibit both low and flat impedance resulting in significantly improved audible performance. The net result is an amplifier that provides stable and reliable operation while providing deeper bass, and more extended highs.

The new bias supply (included) solves common output tube bias drift problems due to the selenium rectifier and leaky capacitors in the stock bias supply. The result is more stability and consistent output tube operation thereby extending their lifetime.

This document describes the specific instructions and steps required to assemble and install the ASM-S7U-B module into either the Dynaco Stereo-70 or Mark 2/3 power amplifier. It may be used with the original Dynaco driver board (PC-3 for the Stereo-70 or PC-1 for the Mark 2/3 amplifiers) or any of our Stereo-70 (ASM-3R or ASM-3U) or Mark 2/3 (ASM-1U) driver modules.



# Dynaco ST-70 & Mark 2/3 Quad-Cap / Power Supply Module Below Chassis Version Assembly, Installation & Setup Manual

CAE QUAD Cap Replacement Module PC-S7U-B & PC-S7U-B-M3 Rev3, 2-11

Page 2

Additional documents referenced (and available from our web page [www.curcioaudio.com](http://www.curcioaudio.com)) are:

- General Overview Assembly Notes (CAE Tech Note # 1)
- Soldering Tutorial (CAE Tech Note # 2)
- Recommended Tools & Test Instruments (CAE Tech Note # 3)

Please take the time to familiarize yourself with all of these documents.

In addition to the assembled board (ASM-S7U-B) you will need the following items to complete this project:

- 1) Three Pin Terminal Strip (center ground)
- 1) Five Pin Terminal Strip (center ground)
- Hook-up wire – Four 10' lengths each of red, black, green, and white, stranded 22ga silver plated copper with Teflon insulation. CAE P/N: TWK will meet this requirement.

**Also, please note that this module houses components that have lethal voltages present on their leads and cases. Please take the appropriate care in both installing and operating this module.**

## II. General Overview

Take time to review all of the documentation provided including the aforementioned tech notes related to soldering technique and proper tools and test equipment. In the following sections we will guide you through several project phases. Each section has been carefully prepared with our own notes and comments from our customers to be sure that any anticipated question has been considered. The sequence is identical to that which we follow when we complete the installation for our customers here in our lab. Please follow the same sequence to maximize efficiency and eliminate errors. It is also very helpful to read each section before beginning to gain a visual idea of the construction.

Your project will be built in stages:

- **Printed Circuit Board (PCB) Assembly** - If you have purchased the PC Board in its unassembled form (PWB-S7U-B) you will first assemble the components onto that board (becomes the ASM-S7U-B for the Stereo-70 or the ASM-S7U-B-M3 for the Mark 2/3). In this stage you will also pre-wire the assembled board.
- **Amplifier Preparation** - Next, you will prepare your amplifier (Stereo-70 or Mark 2/3) by un-wiring (and possibly removing- your choice) the original Dynaco Aluminum



# Dynaco ST-70 & Mark 2/3 Quad-Cap / Power Supply Module Below Chassis Version Assembly, Installation & Setup Manual

Page 3

CAE QUAD Cap Replacement Module PC-S7U-B & PC-S7U-B-M3 Rev3, 2-11

QUAD Aluminum Electrolytic “Can”, the original “selenium” rectifier (the bias supply rectifier), and the associated bias supply caps and resistors and carefully labeling each of the associated wires.

- **Quad Cap Module Installation** - You will then install the CAE replacement ASM-S7U-B Board (or ASM-S7U-B-M3 boards for your Mark 2/3) and reconnect the original wires to their corresponding terminals followed by a few electrical tests and power up sequence.
- **Test & Adjustment** - Finally you will take a few electrical readings to be sure there are no errors and set the amplifier output tube bias (bias pots settings) for each channel.

Although you are unlikely to encounter any problems, should they occur they would almost certainly be based on an improper assembly of the PC Board or the wiring to the Stereo 70. Therefore to avoid the time consuming and frustrating task of troubleshooting afterwards please remember these simple suggestions:

- **Proper soldering is crucial.** Please refer to our soldering tutorial and practice on surplus boards until you master the technique. Be especially careful to avoid solder bridges or “cold” solder joints. Our experience shows that nearly **95% of all problems are associated with soldering related errors.**
- Diodes & Capacitors (the project is full of them) are polar- this means that **there is a right and wrong way to insert polarized components in the board.** If placed backwards, the component and probably others nearby will be damaged upon initial power application. Double check each step associated with these parts and once again later after you have had a chance to take a break.
- Some components are color coded with their value (mostly resistors, but there may be others). If you are not proficient at reading these codes, use an ohmmeter to double check the value of each resistor before insertion. It is very easy to confuse a 100 ohm metal film resistor with a 1000 ohm resistor or worse with a 100K ohm resistor.
- You will need to have some extra hook-up wire for this project to connect to the new module and possibly extend one or more of the power transformer leads. Unless otherwise specified, **you should use 20 to 22 gauge stranded wire with Teflon insulation.** Thicker wire, solid wire, or PVC insulation will cause problems - if not now (too much strain on the boards or parts) or later (reliability issues). CAE offers a Teflon Wire Kit (#TWK) that includes sufficient lengths of various color Teflon wire to complete this project.



# Dynaco ST-70 & Mark 2/3 Quad-Cap / Power Supply Module Below Chassis Version Assembly, Installation & Setup Manual

Page 4

CAE QUAD Cap Replacement Module PC-S7U-B & PC-S7U-B-M3 Rev3, 2-11

## III. Stage 1 - Printed Circuit Board Assembly

The PC assembly section describes the assembly of your blank PC boards. (If you have purchased your boards pre-assembled (ASM-S7U-B or ASM-S7U-B-M3) you should proceed to the associated wire attachment section (B or C). The first section (A) describes the installation of components common to both amplifiers and therefore needs to be completed in all instances. The following two section (B and C) are specific to either the Stereo-70 amplifier (section B) or the Mark 2/3 amplifier (section C).

### A. This section to be completed for all installations (both the Stereo-70 or Mark 2/3 amplifiers)

Components are to be inserted on the non foil side and soldered on the foil side. The sequence of assembly has been chosen so that the components with the lowest profile (such as jumpers, small resistors resistors, IC's etc.) are installed first with higher profile components added until the highest profile components are installed last.

Refer to the component placement drawing (Figure 1). Be sure to observe correct orientation of polar components (capacitors). Be sure also to check with an ohmmeter resistor values if you are not absolutely sure of how to read film resistor color codes.

1. Install the five 1N4007 diodes (D1 through D5). Be sure to observe the correct polarity (diode polarity is indicated by a white band at one end of the diode)
2. Install the four 470K ohm ½ watt resistors (R1, R2, R3 and R4).
3. Install the four 330K ohm ½ watt resistors (R6, R8, R10 and R12).
4. Install the four 220K ohm ½ watt resistors (R5, R7, R9 and R11).
5. Install the four 100uF @ 250V electrolytic capacitors (C1, C3, C5 and C7). It is critically important that you observe correct polarity. The negative terminal is identified by a black stripe along the edge nearest the negative terminal. Note- these capacitors are identical in size to the 47uF @ 350V parts – be sure you have selected the correct component.
6. Install the two 47uF @ 350V electrolytic capacitors (C6 and C8). It is critically important that you observe correct polarity. The negative terminal is identified by a black stripe along the edge nearest the negative terminal. Note- these capacitors are identical in size to the 100uF @ 250V parts – be sure you have selected the correct component.
7. Install the two 100uF @ 350V electrolytic capacitors (C2 and C4). It is critically important that you observe correct polarity. The negative terminal is identified by a black stripe along the edge nearest the negative terminal.
8. Install the two 47uF @ 100V electrolytic capacitors (C9 and C10). It is critically important that you observe correct polarity. The negative terminal is identified by a black stripe along the edge nearest the negative terminal.



# Dynaco ST-70 & Mark 2/3 Quad-Cap / Power Supply Module Below Chassis Version Assembly, Installation & Setup Manual

Page 5

CAE QUAD Cap Replacement Module PC-S7U-B & PC-S7U-B-M3 Rev3, 2-11

9. Install the 6.8K / 2W power resistor (R13). Note that this resistor should be positioned so that it is spaced from the surface of the PC Board by approximately 1/8".

**B. This section to be completed for the Stereo-70 amplifier. If you are using the S7U-B module in a Mark 2/3 amplifier skip to section C below. Refer to the upper table (Stereo 70) in Figure 1.**

1. Install a 22K ohm, 2W resistor in position R14.
2. The two resistors at positions R15 and R16 determine the operation of the amplifier bias set potentiometer. There are three possible operational conditions that you may configure with our module.
  - a. You can have your Stereo-70 bias set potentiometer function exactly as the stock amplifier. In this case:
    - i. R15 = 10K ohm, 1W
    - ii. R16 = 10K ohm, 1W
  - b. You can expand the bias range of the bias set potentiometer. This is useful to accommodate a wide variety of tube characteristics which may include both new manufacture tubes as well as NOS tubes that have a wide tolerance of gain specifications and therefore bias requirements. In this case:
    - i. R15 = 6.2K ohm, 1W
    - ii. R16 = 6.2K ohm, 1W
  - c. For those who have purchased one of our upgrade or premium driver modules (ASM-3U or ASM-3A) with the "Balance-Bias" option, install the following resistors:
    - i. R15 = 4.7K ohm, 1W
    - ii. R16 = 7.5K ohm, 1W

3. S7U-B Board Prewire Steps - **Refer to Figure 2A**

Before you physically install your capacitor module, it is convenient to pre-wire all of the terminals that will connect inside of your power amplifier. As noted before, we strongly recommend using 22ga stranded silver plated copper wire with Teflon insulation. We find that it is relative easy and reliable to make each connection by stripping 1/4" of insulation from the end of the wire and then making the connection by laying the wire in a "pool" of solder at the assigned terminal. Orient the wire is indicated in the following instructions.

For this section, you will refer to Figure 2A. NOTE: White wires are shown a VIOLET for clarity.

# Dynaco ST-70 & Mark 2/3 Quad-Cap / Power Supply Module Below Chassis Version Assembly, Installation & Setup Manual

- a. GND Terminal - Connect a 10" length of Black wire to the GND terminal. Orient towards the "HA1" terminal
- b. C Terminal - Connect an 11" piece of White (illustrated as Violet) wire to the "C" terminal. Orient towards the "HA1" terminal.
- c. BA Terminal - Connect a 9" piece of Green wire to the "BA" terminal. Orient towards the "B+" terminal
- d. Twist together the Black, Green and White wires from the last three steps
- e. B Terminal - Connect a 13" piece of Green wire to the "B" terminal. Orient towards the "HA1" terminal.
- f. A Terminal - Connect a 13" piece of Red wire to the "A" terminal. Orient towards the "HA2" terminal.
- g. Twist together the 13" Red & Green wires from the last two steps.
- h. HA1 Terminal - Connect a 4" piece of Red wire to the "HA1" terminal. Orient towards the "BA" terminal.
- i. HA2 Terminal - Connect a 4" piece of Red wire to the "HA2" terminal. Orient towards the "BA" terminal.
- j. Twist together the two 4" Red wires from the last two steps.
- k. D Terminal - Connect a 5" piece of White wire to the "D" terminal. Orient towards the "B" terminal.
- l. Twist together the 2 Red & White wires from the last three steps
- m. Connect a 9" piece of Green wire to the "B+" terminal. Orient towards the "BA" terminal
- n. Connect a 9" piece of Black wire to the "B-" terminal. Orient towards the "BA" terminal
- o. Twist together the 9" Black & Green wires from the last two steps.
- p. Although not necessary, you may notch out the two mounting holes near the edge of the pc board at this time. Keep the width approximately the same as the hole diameter. This will make the physical installation much easier and therefore is recommended.

Visually inspect all of your solder connections. Refer to the adjacent diagram. Quality solder connections should be smooth and shiny. Dull surface or large blobs on the PC board should be cleaned and resoldered. In this case remove the old solder with solder wick or similar and resolder the connection.

**C. This section to be completed for the Mark 2/3 amplifiers. If you are using the S7U-B module in a Stereo-70 amplifier refer back to the preceding section B. Refer to the lower table (Mark 2/3) in Figure 1.**

1. Do not install any device in position R14.
2. The two resistors at positions R15 and R16 determine the operation of the amplifier bias set potentiometer. There are two possible operational conditions



# Dynaco ST-70 & Mark 2/3 Quad-Cap / Power Supply Module Below Chassis Version Assembly, Installation & Setup Manual

CAE QUAD Cap Replacement Module PC-S7U-B & PC-S7U-B-M3 Rev3, 2-11

Page 7

that you may configure with our module. Note – there is no bias expansion option available for the Dynaco Mark 2/3 power amplifier and therefore there are only two possible options:

- a. You can have your Dynaco Mark 2/3 power amplifier bias set potentiometer function exactly as the stock amplifier. In this case:
  - i. R15 = 1K ohm, 1W
  - ii. R16 = 18K ohm, 1W
- b. For those who have purchased one of our upgrade or premium driver modules (ASM-3U or ASM-1A) with the “Balance-Bias” option, install the following resistors:
  - i. R15 = 10 ohm, 1W
  - ii. R16 = 22K ohm, 1W

### 3. ASM-S7U-B-M3 Board Prewire. **Refer to Figure 2B**

Before you physically install your capacitor module, it is convenient to pre-wire all of the terminals that will connect inside of your power amplifier. As noted before, we strongly recommend using 22ga stranded silver plated copper wire with Teflon insulation. We find that it is relative easy and reliable to make each connection by stripping ¼” of insulation from the end of the wire and then making the connection by laying the wire in a “pool” of solder at the assigned terminal. Orient the wire is indicated in the following instructions. Refer to Figure 2B:

For this section, you will refer to Figure 2B. NOTE: White wires are shown a VIOLET for clarity.

- a. GND Terminal - Connect a 12” length of Black wire to the GND terminal. Orient towards as shown in Figure 2B.
- b. BA Terminal - Connect a 15” piece of Green wire to the “BA” terminal. Orient towards the GND terminal and as shown in Figure 2B.
- c. Twist together the two wires from the last two steps.
- d. B Terminal - Connect a 4” piece of Green wire to the “B” terminal. Orient towards the “HA1” terminal.
- e. A Terminal - Connect a 4” piece of Red wire to the “A” terminal. Orient towards the “HA1” terminal.
- f. Twist together the 4” Red & Green wires from the last two steps.
- g. HA1 Terminal - Connect a 5” piece of Red wire to the “HA1” terminal. Orient towards the “BA” terminal.
- h. HA2 Terminal - Connect a 5” piece of Red wire to the “HA2” terminal. Orient towards the “BA” terminal.



# Dynaco ST-70 & Mark 2/3 Quad-Cap / Power Supply Module Below Chassis Version Assembly, Installation & Setup Manual

Page 8

CAE QUAD Cap Replacement Module PC-S7U-B & PC-S7U-B-M3 Rev3, 2-11

- i. D Terminal - Connect a 6" piece of White wire to the "D" terminal. Orient towards the "B" terminal
- j. Twist together the three wires from the last three steps.
- k. B+ Terminal - Connect a 6" piece of Green wire to the "B+" terminal. Orient towards the "BA" terminal
- l. B- Terminal - Connect a 6" piece of Black wire to the "B-" terminal. Orient towards the "BA" terminal
- m. Twist together the 6" Black & Green wires from the last two steps.
- n. C Terminal - Do not connect any wires to terminal "C" now. Once the board is installed, you will connect two wires to this pad:
  - i. Output Transformer Red wire
  - ii. Choke Lead #2
- o. Although not necessary, at this time you may notch out the two mounting holes near the edge of the pc board. Keep the width approximately the same as the hole diameter. This will make the physical installation much easier and therefore is recommended.

Visually inspect all of your solder connections. Refer to the adjacent diagram. Quality solder connections should be smooth and shiny. Dull surface or large blobs on the PC board should be cleaned and resoldered. In this case remove the old solder with solder wick or similar and resolder the connection.

## IV. Stage 2 - Amplifier Preparation

### A. Stereo-70 Amplifier Preparation

In this section, we will describe the steps to prepare your Stereo-70 amplifier to receive the ASM-S7U-B capacitor module. If you are installing this module in a Mark2/3 amplifier, skip to the next section (B).

**Please refer to Figure 4A.** Orient your amplifier so that you are viewing the amplifier from the bottom with all three transformers sitting on your bench.

NOTE: You will be desoldering some of the original Dynaco wires in this section. These wires use PVC insulation that is not very tolerant of the heat from your soldering iron. In some cases the original wire will be retained therefore it is very important that you take care to not melt this insulation

There are three sections of your amplifier that we will be removing or prepping in this section:

- The original dynaco "quad capacitor" (located to the right of the right channel bias adjustment potentiometer)





# Dynaco ST-70 & Mark 2/3 Quad-Cap / Power Supply Module Below Chassis Version Assembly, Installation & Setup Manual

Page 9

CAE QUAD Cap Replacement Module PC-S7U-B & PC-S7U-B-M3 Rev3, 2-11

- The 7 Pin terminal Strip (located under the left output transformer)
- The selenium rectifier (located between the left and right bias adjustment potentiometers)

Quad Capacitor Removal - We will begin amplifier preparation by un-wiring of the original dynaco “quad” capacitor. The original dynaco “quad” capacitor had four outer tabs that insert into the chassis and provide the “ground” reference for all four internal capacitors. The inner terminals are the “positive” terminals of each internal capacitor and are identified by symbols adjacent to each. The symbols are Square, Round, Triangle and None. The Figure 4A also adds labels 1,2,3 and 4 – we will use the number references since not all amplifiers may have been assembled correctly. In the following steps, we will refer to each lug by its symbol (as shown on the associated diagram referenced).

1. At the # 3 (Square) Lug, cut the 22K ohm resistor lead.
2. At the #3 (Square) Lug, cut the wire leading to terminal 19 on the dynaco printed circuit board. At the pc board terminal 19, desolder the other end of this wire and discard.
3. At the #4 (Triangle Lug), cut the two resistor leads (22K ohm from step 1, and 6.8K ohm resistor lead). Discard the 22K ohm resistor.
4. At the #4 (Triangle) lead, cut the wire leading to terminal 20 on the dynaco printed circuit board. At the pc board terminal 20, desolder the other end of this wire and discard.
5. At the #2 (Round) Lug, carefully Desolder the wire that connects to Pin 8 of the GZ34 rectifier tube (V1). Be careful to not melt the insulation when you desolder this wire. Label this wire as “D”.
6. At the #2 (Round) Lug, desolder the choke wire and label it as choke lead “D”. Be careful to not melt the insulation when you desolder this wire.
7. At the #1 Lug (without any indicator), cut the other end of the 6.8K resistor and discard.
8. At the #1 Lug (without any indicator), desolder the other choke lead and label as choke lead “C”. Be careful to not melt the insulation when you desolder this wire.
9. At the #1 Lug (without any indicator), desolder the **two** remaining red wires (leading to the output transformers) and label each as “C”. Be careful to not melt the insulation when you desolder these wires.
10. Remove the original Dynaco quad electrolytic capacitor. To do this it may be necessary to de-solder one or more of the ground (outer) tabs. You may retain the original Dynaco “quad” capacitor if you wish for aesthetic reasons.

7 Pin Terminal Strip Removal - Now we will disconnect and remove the 7 Pin terminal strip (located under the left output transformer). The Figure 4A identifies each of the terminals from 1 through 7 – we will use these reference labels in our instructions below :



# Dynaco ST-70 & Mark 2/3 Quad-Cap / Power Supply Module Below Chassis Version Assembly, Installation & Setup Manual

Page 10

CAE QUAD Cap Replacement Module PC-S7U-B & PC-S7U-B-M3 Rev3, 2-11

1. Terminal #1 – no action needed
2. Terminal #2 – Cut the wire that leads to left bias pot terminal #3. Desolder the other end of this wire at the left bias pot terminal #3. Be careful not to melt the insulation on the remaining wire at the pot terminal.
3. Terminal #2 – no further action needed.
4. Terminal #3 - Cut the wire that leads to left bias pot terminal #1. Desolder the other end of this wire at the left bias pot terminal #1. Be careful not to melt the insulation on the remaining wire at the pot terminal.
5. Terminal #3 – no further action needed.
6. Terminal #4 – Cut at wire that leads to the selenium rectifier. Cut the other end of this wire at the selenium rectifier.
7. Terminal #5 – Carefully de-solder the lead of the dual 0.02 ceramic capacitor (note that we will re-use this component).
11. Terminal #5 – De-solder the Green-Yellow power transformer lead. Be careful to not melt the insulation when you desolder this wire.
8. Terminal #6 – Carefully de-solder the center lead of the 0.02 ceramic capacitor.
9. Terminal #6 – Cut and discard the wire that leads to the ground lug near the dynaco quad capacitor. Cut the other end of thie wire at the ground lug.
10. Terminal #7 – Carefully de-solder the lead of the dual 0.02 ceramic capacitor (note that we will re-use this component).
12. Terminal #7 – De-solder the Brown-Yellow power transformer lead. Be careful to not melt the insulation when you desolder this wire.
11. Remove the 7 Pin terminal strip by remoing the two 4-40 nuts. Note that the two screws originate from under the left output transformer and will be retained. The 4-40 nuts will be used in the next step.
12. Install the two “L” brackets using the drilled (un-threaded) hole of the “L” bracket such that the high side of the “L” threaded hole is facing the front of the amplifier. Secure tightly using the 4-40 nuts from the previous step.
13. Place two 6-32 X ¼” (no longer) screws into the threaded holes of the “L” bracket (from the direction of the front of the amplifier)

5 Pin Terminal Strip (5PTS) Installation - We will now install the new 5 pin terminal strip. **Refer to Figure 3A** for this section. It will be mounted in the chassis hole now used for the grounding lugs (located between the original quad capacitor and the right bias set potentiometer – see Figure 3A).

1. Carefully desolder all of the wires currently connected to the ground lugs. These should include:
  - a. Speaker “0” terminals (quantity 2)
  - b. Ground wire from terminal 9 of the 7199 driver board
  - c. Power Transformer Red-Yellow lead
  - d. All other ground connection wires may be discarded
2. Remove the ground lugs and retain both lugs and hardware

# Dynaco ST-70 & Mark 2/3 Quad-Cap / Power Supply Module Below Chassis Version Assembly, Installation & Setup Manual

3. Install the 5 pin terminal strip at this same location using the 4-40 hardware from the previous step. Orient as shown in Figure 3A.
4. 5PTS- Terminal #4 - Locate the original Dynaco wire connected to pin 8 of V1 (GZ34 rectifier). Route carefully and connect to the 5 pin terminal strip terminal # 4.
5. 5PTS Terminal #4 - Locate the two choke leads. Twist together and route carefully towards terminals #4 & #5 of the 5 pin terminal strip (previously mounted and located near the right bias set pot). Trim to length and connect one choke lead to terminal #4.
6. 5PTS Terminal # 5 - Trim to length and connect the remaining choke lead to terminal #5.
7. 5PTS Terminal # 5 - Locate the LEFT Output transformer RED lead. Trim to length and connect to terminal #5 of the 5 pin terminal strip. Note that it may be necessary to extend the length of this lead. If so please use 22ga Teflon wire, soldering the connection and insulating with 1/8" shrink tubing.
8. 5PTS Terminal # 5 - Locate the RIGHT Output transformer RED lead. Trim to length and connect to terminal #5 of the 5 pin terminal strip.
9. 5PTS Terminal # 3 - Locate the ground wire connected to the RIGHT speaker "0" terminal. Trim to length and connect to terminal #3 (ground center) of the 5 pin terminal strip.
10. 5PTS Terminal # 3 - Locate the ground wire connected to the LEFT speaker "0" terminal. Trim to length and connect to terminal #3 (ground center) of the 5 pin terminal strip.
11. 5PTS Terminal # 3 - Locate the ground wire connected to the terminal # 9 of the Dynaco 7199 driver pc board. Trim to length and connect to terminal #3 (ground center) of the 5 pin terminal strip.
12. 5PTS Terminal # 1 - Locate the POWER Transformer RED-BLACK lead and connect to terminal #1 of the 5 pin terminal strip (see Figure 3A).

**Selenium Rectifier Removal & Installation of the Three Pin Terminal Strip (3PTS)** - Now we will disconnect and remove the Selenium rectifier (located at the center of the amplifier between the two bias set potentiometers) and install in the same location a 3 pin terminal strip (3PTS). Reference Figure 4A (steps 1& 2) and Figure 3A(steps 3-7).

1. Desolder the power transformer Red-Black lead.
2. Remove the selenium rectifier and discard. Remove and retain the associated 4-40 hardware.
3. Install the new 3 Pin terminal strip as shown in Figure 3A using the same hole originally used for the selenium rectifier. Orient so that the high side of the 3 pin terminal strip is nearest the front side of your amplifier.
4. Locate the dual 0.02uF disc capacitor previously removed from the 7 pin terminal strip and install to the 3 pin terminal strip now located between the two bias



# Dynaco ST-70 & Mark 2/3 Quad-Cap / Power Supply Module Below Chassis Version Assembly, Installation & Setup Manual

Page 12

CAE QUAD Cap Replacement Module PC-S7U-B & PC-S7U-B-M3 Rev3, 2-11

- adjustment pots. Refer to Figure 3A. The two outer leads should be connected to the two outer terminals while the center lead should be connected to the center (ground) terminal.
5. 3PTS Terminal # 1 - Locate and trim to length the Brown-Yellow power transformer lead and connect to terminal 1 of the 3 pin terminal strip (see fig 3A)
  6. 3PTS Terminal # 3 - Locate and trim to length the Green-Yellow power transformer lead and connect to terminal 3 of the 3 pin terminal strip (see fig 3A)
  7. 3PTS Terminal # 2 - Locate and trim to length the RED-YELLOW POWER transformer lead and connect to the center (ground) terminal of the 3 pin terminal strip (see figure 3A).

## **B. Dynaco Mark 2 /3 Amplifier Preparation**

In this section, we will describe the steps to prepare your Mark 2/3 amplifiers to receive the ASM-S7U-B-M3 capacitor modules. If you are installing in a Stereo-70 amplifier, please refer to the previous section.

**Please refer to Figure 4B** . From the bottom of your amplifier, orient you amplifier so that the speaker terminals are to your left and the transformers are sitting on your bench.

NOTE: You will be desoldering some of the original Dynaco wires in this section. These wires use PVC insulation that is not very tolerant of the heat from your soldering iron. In some cases the original wire will be retained therefore it is very important that you take care to not melt this insulation

There are three sections of your amplifier that we will be removing or prepping in this section:

- The original dynaco “quad capacitor” (located in the upper right hand corner of the amplifier.
- The 3 Pin terminal Strip (located to the right of the fuse holder)
- The selenium rectifier (below output tube V2)

Quad Capacitor Removal - We will begin amplifier preparation by un-wiring of the original dynaco “quad” capacitor. The original dynaco “quad” capacitor had four outer tabs that insert into the chassis and provide the “ground” reference for all four internal capacitors. The inner terminals are the “positive” terminals of each internal capacitor and are identified by symbols adjacent to each. The symbols are Square, Round, Triangle and None. The referenced Figure 4B also adds labels 1, 2, 3 and 4 – we will use the number references since not all amplifiers may have been assembled correctly



# Dynaco ST-70 & Mark 2/3 Quad-Cap / Power Supply Module Below Chassis Version Assembly, Installation & Setup Manual

Page 13

CAE QUAD Cap Replacement Module PC-S7U-B & PC-S7U-B-M3 Rev3, 2-11

1. At the #4 Lug (without any indicator), cut the 6.8K ohm resistor lead.
2. At the #4 Lug (without any indicator), cut the wire that leads to terminal 5 on the dynaco printed circuit board. At the pc board, desolder the other end of this wire at terminal 5 and discard.
3. At the #3 (Triangle) lead, cut the wire that leads to terminal 6 on the dynaco printed circuit board. At the pc board terminal 5, desolder the other end of this wire and discard.
4. At the #1 (Round) Lug, cut the wire that lead to Pin 8 of the GZ34 rectifier tube (V1). Desolder this wire at pin 8 of the GZ34.
5. At the #2 (Square) Lug, cut the other end of the 6.8K resistor and discard.
6. At the #2 (Square) Lug, desolder the other choke lead and label as choke lead "C". Be careful to not melt the insulation when you desolder this wire.
7. At the #2 (Square) Lug, desolder the red wire (leading to the output transformer) and label as "D". Be careful to not melt the insulation when you desolder this wire.
8. One of the Quad capacitor Ground Lugs will have a 15.6 ohm bias-set resistor connection (the exact lug is variable depending on the original assembly). Desolder this lead and reconnect to a nearby ground lug on the nearest octal tube socket (V1, V2 or V3).
9. Remove the original Dynaco quad electrolytic capacitor. To do this it may be necessary to de-solder one or more of the ground (outer) tabs. You may retain the original Dynaco "quad" capacitor if you wish for aesthetic reasons.

3Pin Terminal Strip (3PTS) Connections - Next we will address the connections to the 3 Pin terminal strip (located to the right of the fuse holder). Referring to figure 4B each terminal is represented by an associated number label from 1 through 3. In the following steps, we will reference the terminal addressed by its terminal number:

1. Terminal #1 – no action needed
2. Terminal #2 – Desolder the lead from the 50uF electrolytic capacitor. The other end of this capacitor connects to the selenium rectifier – it can be cut at this end and discarded.
3. Terminal #3. Desolder the wire whose other end leads to the bias potentiometer terminal #3. Desolder the other end of this wire at bias potentiometer terminal # 3 and discard. Be careful when you are desoldering this wire at the pot end to not melt the other wire connected to this pot terminal.
4. Terminal #3 – Desolder the 1K ohm resistor whose other end connects to the selenium rectifier.
5. Terminal # 3 – Connect the Power Transformer RED-BLK lead to terminal # 3.

Selenium Rectifier Removal - We will now address the selenium rectifier located between the output tubes and the 3Pin terminal strip.



# Dynaco ST-70 & Mark 2/3 Quad-Cap / Power Supply Module Below Chassis Version Assembly, Installation & Setup Manual

Page 14

CAE QUAD Cap Replacement Module PC-S7U-B & PC-S7U-B-M3 Rev3, 2-11

1. Desolder the Red-Black power transformer wire connected to one of the selenium rectifier terminals. Be careful to not melt the insulation when you desolder this wire.
2. Remove the selenium rectifier and discard. Retain the 4-40 hardware.

Bias Set Potentiometer Connections - Next, we will address the connections to the bias set potentiometer (located between both output tubes). Note that in the diagram the terminals are labeled 1,2, and 3 and we will reference our steps to these terminal numbers.

1. Terminal #1 Desolder the 18K ohm resistor whose other end connects to the chassis ground. Desolder the other end of this resistor at ground and discard.
2. Terminal #2 – Desolder the 50uF electrolytic capacitor whose other end connects to chassis ground. Desolder the other end of this capacitor at ground and discard. Be careful to not melt the insulation from the other wire connected to this terminal.
3. Terminal #3 – The wire at this terminal previously connected to the 3 Pin terminal strip #3. If you have not previously desoldered this wire, do so now and discard.

“L” Bracket Installation (**Refer to Fig 3B**) - You will now mount the “L” bracket that secures your Quad capacitor module. In the MK-3 installation, only one mounting hole is used to mount the ASM-S7U-B-M3 module. (At your discretion you may elect to drill an additional hole to mount the second “L” bracket. In this case you can position the board to identify the location of the second mounting hole.) This bracket will be located at the chassis hole now used to clamp the group of output transformer leads as they route to the two output tubes. This is also used to mount one of the four output transformer tabs (top side of the chassis).

1. Remove the 8-32 nut and screw holding the clamp for all of the output transformer wires leading to the output tubes. You will need to re-route this wire bundle as far to the right as possible (towards the choke) and secure with a nylon wire tie. Re-install this clamp on the north-west mounting screw for the power transformer and situate the wires so that there is sufficient clearance for the capacitor module.
2. Using the non-threaded hole and 6-32 hardware, mount one of the supplied “L” brackets at this location and orient such that the high side of the “L” bracket is nearest the output tubes. The screw should include a suitable washer to be sure to capture the full mounting hole of the output transformer on the top side of the chassis.





# Dynaco ST-70 & Mark 2/3 Quad-Cap / Power Supply Module Below Chassis Version Assembly, Installation & Setup Manual

Page 15

CAE QUAD Cap Replacement Module PC-S7U-B & PC-S7U-B-M3 Rev3, 2-11

You have successfully completed the preparation of your amplifier. The next section will describe the installation and wiring of your new power supply module.

## V. Stage 3 – Quad Capacitor Power Supply Module Installation

### A. Installation of the ASM-S7U-B into your Stereo -70 amplifier.

In this section, we will describe the steps to install the ASM-S7U-B capacitor module into your Dynaco Stereo 70 amplifier. If you are installing in a Mark2/3 amplifier, skip to the next section. **Please refer to Figure 3A.**

You will now mount and wire the ASM-3U-B quad cap module:

1. Locate the CAE replacement Driver board (ASM-S7U-B). You should have previously installed the 10 wires that will be connected to various points within the Stereo 70.
2. Using two 6-32 X 1/4" screws (no longer) mount the ASM-S7U-B module to the angle brackets (previously mounted) so that the components face the rear (speaker terminals) and the foil faces the front (output tubes) of the amplifier. Observe the following sequence:
  - a. Screw
  - b. PC-S7U-B (foil side)
  - c. Angle Bracket (threaded hole)
3. I suggest inserting the first screw a few turns but not fully tight. Then install the remaining screw and tighten. Now go back and tighten the first screw. It is critical that the board be flush with the chassis bottom (there should be no wires or debris positioned between the board edge and the chassis). If you have previously notched out the mounting holes you can easily slip the boards onto the brackets and tighten the two screws.
4. As illustrated in Figure 3A, begin wiring the wires from the PC-S7U-B module to their associated points within the amplifier. If you are retaining the original tube rectifier, do not connect either the "HA1 or HA2 leads at this time. In this case cover each with either a short piece of shrink tubing or quality electrical tape. **If you will be using the ASM-S7U-B solid state rectification (not using the GZ34 rectifier tube), you should connect HA1 to pin 4 of the rectifier tube socket and HA2 to pin 6 of the rectifier tube socket. Otherwise these wires are to be left un-terminated (and insulated)**
5. Locate the White wire (the figure shows it as Violet) wire from the ASM-S7U-B terminal "D" and connect to V1 (GZ34) tube pin # 8 (see figure 3A).
6. Route the Green & Black twisted pair wires (from terminals B+ and B-) as shown and connect to the left bias pot as shown.
  - a. B+ (green) should connect to pot terminal #3 while





# Dynaco ST-70 & Mark 2/3 Quad-Cap / Power Supply Module Below Chassis Version Assembly, Installation & Setup Manual

Page 16

CAE QUAD Cap Replacement Module PC-S7U-B & PC-S7U-B-M3 Rev3, 2-11

- b. B- (black) should connect to pot terminal # 1.
7. Locate the twisted wire group containing ASM-3U-B terminal wires GND, C and BA and route as shown. Make the following connections:
  - a. Connect the Black GND wire to the 3 pin terminal strip terminal #2
  - b. Connect the Green “BA” wire to the 5 pin terminal strip terminal #1.
  - c. Connect the White “C” wire to the 5 pin terminal strip terminal # 5.
8. Locate the Red & Green twisted pair wires (from terminals A and B) and route as shown in figure 3A.
  - a. Connect the Red wire to the Dynaco 7199 driver board (PC-3) terminal # 19.
  - b. Connect the Green wire to the Dynaco 7199 driver board (PC-3) terminal # 20.

## **B. Installation of the ASM-S7U-B-M3 into your Mark 2/3 amplifiers. Refer to Figure 3B.**

In this section, we will describe the steps to install the ASM-S7U-B-M3 capacitor module into your Dynaco Mark 2/3 amplifiers. If you are installing in a Stereo 70 amplifier please refer to the preceding section (A). Refer to Figure 3B :

The ASM-S7U-B capacitor module will be mounted to the underside of your Mark 2/3 using the same hole that is shared with the north-east corner of the output transformer. Consult Figure 3B – it shows the approximate location (however it shows the board lying down as opposed to the correct perpendicular installation orientation). The board will be orientated at right angle to the bottom surface of the chassis with the foil of the board facing the 6AN8 driver PC board (PC-1) with the component side of the cap board facing towards the fuse holder. Note – only the bracket near the “B” terminal will be secured to the chassis – the bracket near the “GND” terminal will not be fastened to the chassis unless you elect to drill a second mounting hole. When you removed the north-east mounting screw for the output transformer (originally a 10-32 screw) you also removed a wire clamp that was holding some transformer leads. Re-install this clamp on the north-west mounting screw for the power transformer and situate the wires so that there is sufficient clearance for the capacitor module.

1. Locate the CAE replacement Driver board (ASM-S7U-B-M3). You should have previously installed the 10 wires that will be connected to various points within the Mark 2/3.
2. Using a 6-32 X ¼” screw (no longer) mount the remaining right angle bracket to the foil side of the pc board against the foil side surface so that the bracket point in the away from the board surface. This should be mounted to the mounting hole nearest the “GND” terminal of the module.



# Dynaco ST-70 & Mark 2/3 Quad-Cap / Power Supply Module Below Chassis Version Assembly, Installation & Setup Manual

Page 17

CAE QUAD Cap Replacement Module PC-S7U-B & PC-S7U-B-M3 Rev3, 2-11

3. Using a 6-32 X 1/4" screw, mount the ASM-3U-B-M3 board to the "L" bracket previously installed in your amplifier. Observe the following sequence:
  - a. Screw
  - b. PC-S7U-B (foil side)
  - c. Angle Bracket (threaded hole)
4. I suggest inserting the screw first into the bracket a few turns but not fully tight. Make sure you have the board flush with the bottom of the chassis (there should be no wires or debris positioned between the board edge and the chassis). Now go back and tighten the first screw. It is critical that the board be flush with the chassis bottom. If you have previously notched out the mounting holes you can easily slip the boards onto the brackets and tighten the screw.
3. As illustrated in Figure 3B, begin wiring the wires from the ASM-S7U-B-M3 module to their associated points within the amplifier. If you are retaining the original tube rectifier, do not connect either the "HA1 or HA2 leads at this time. In this case cover each with either a short piece of shrink tubing or quality electrical tape. **If you will be using the ASM-S7U-B-M3 solid state rectification (not using the GZ34 rectifier tube), you should:**
  - a. **Connect HA1 to pin 4 of the rectifier tube socket and**
  - b. **Connect HA2 to pin 6 of the rectifier tube socket. Otherwise these wires are to be left un-terminated (and insulated)**
4. Locate the White wire (the figure shows it as Violet) wire from the ASM-S7U-B-M3 terminal "D" and connect to V3 (GZ34) tube pin # 8 (see figure 3B).
5. Route the Green & Black twisted pair wires (from terminals B+ and B-) as shown and connect to the bias pot as shown.
  - a. B+ (green) should connect to pot terminal #4 while
  - b. B- (black) should connect to pot terminal # 3.
6. Locate the twisted pair containing ASM-3U-B-M3 terminal wires GND and BA and route as shown in figure 3B. Make the following connections:
  - a. Connect the Black GND wire to the 3 pin terminal strip terminal #2
  - b. Connect the Green "BA" wire to the 3 pin terminal strip terminal #3.
7. Locate the OUTPUT transformer RED wire and connect to ASM-3U-B-M3 terminal "C".
8. Locate the un-terminated choke wire (labeled "C") and connect also to ASM-3U-B-M3 terminal "C".
9. Locate the Red & Green twisted pair wires (from terminals A and B) and route as shown in figure 3B.
  - a. Connect the Red wire to the Dynaco 6AN8 driver board (PC-1) terminal # 6.
  - b. Connect the Green wire to the Dynaco 6AN6 driver board (PC-1) terminal # 5



# Dynaco ST-70 & Mark 2/3 Quad-Cap / Power Supply Module Below Chassis Version Assembly, Installation & Setup Manual

Page 18

CAE QUAD Cap Replacement Module PC-S7U-B & PC-S7U-B-M3 Rev3, 2-11

## VI. Stage 4 – Final Checkout & Initial Power Application

1. Replace the power fuse (3A Slo-Blo) with a 1A Slo-Blo to perform the start up test sequence. Install the driver tubes (2x 7199 for the Stereo-70 or 1x 6AN8 for the MK-2/3).
2. If you are not using the solid state rectifier option, plug in the rectifier tube. Please note, if you are using the solid state rectifier option DO NOT INSTALL THE RECTIFIER (GZ34) TUBE. Connect a voltmeter to pin 8 of the rectifier tube. The negative lead (Black) should be connected to the amplifier chassis. The positive lead (Red) should be connected to pin 8 of the rectifier tube. Set the voltmeter to measure 500 Volts DC.
3. Plug in and apply power to the amplifier. The voltage reading should be approximately 475 to 550 VDC. If you are using a tube rectifier, this reading should appear after approximately 30 seconds – if you are using the solid state option, it should appear immediately.
4. Measure the voltages at the outer terminals of one of the bias potentiometers. For a Stereo-70 at one terminal (the – BIAS) you should measure approximately – 39 VDC. At the other terminal (the + BIAS) you should measure approximately – 26 VDC. (For the Mark 2/3 you should measure -67 VDC and – 45 VDC respectively.) A reading within 10% is acceptable. If you do not measure these values do not proceed – check out the bias capacitors and the wiring associated with power transformer lead “RED-BLK”. Power down and wait 15 minutes.
5. For the Stereo-70:

Place RCA shorting plugs into the signal input(s) of your amplifier. Install the two left channel output tubes. Do not install the right channel output tubes right now. Replace the original 3A fuse. Rotate both original Bias Potentiometers fully counterclockwise. Connect your DC Voltmeter to monitor the current thru the output tubes by measuring the voltage across the 15.6 ohm resistor located at pins 1 & 8 of the output tubes - connect the negative lead (Black) to the chassis and connect the Positive lead (Red) to the junction of the 15.6 ohm resistor and the Output Tube pins 1 & 8. Monitor the voltage as the tubes reach operating temperature. If the voltage begins to exceed 2.5 volts quickly remove power. Otherwise adjust the Bias pot to obtain 1.56 volts. Remove power.

6. Install the right channel output tubes, apply power, and repeat the procedure outlined in step 3. Recheck the bias on the left channel. Remove power.



# Dynaco ST-70 & Mark 2/3 Quad-Cap / Power Supply Module Below Chassis Version Assembly, Installation & Setup Manual

CAE QUAD Cap Replacement Module PC-S7U-B & PC-S7U-B-M3 Rev3, 2-11

Page 19

## 7. For the Mark 2/3:

Place a RCA shorting plug into the signal input of your amplifier. Install the two output tubes. Replace the original 3A fuse. Rotate the original Bias Potentiometer fully counterclockwise. Connect your DC Voltmeter to monitor the current thru the output tubes by measuring the voltage across the 11.2 ohm resistor located at pins 1 & 8 of the output tubes - connect the negative lead (Black) to the chassis and connect the Positive lead (Red) to the junction of the 11.2 ohm resistor and the Output Tube pins 1 & 8. Monitor the voltage as the tubes reach operating temperature. If the voltage begins to exceed 2.5 volts quickly remove power. Otherwise adjust the Bias pot to obtain 1.56 volts. Remove power.

## 8. Replace the cover and enjoy.

## CAE PC-S7U-B Schematic Diagram

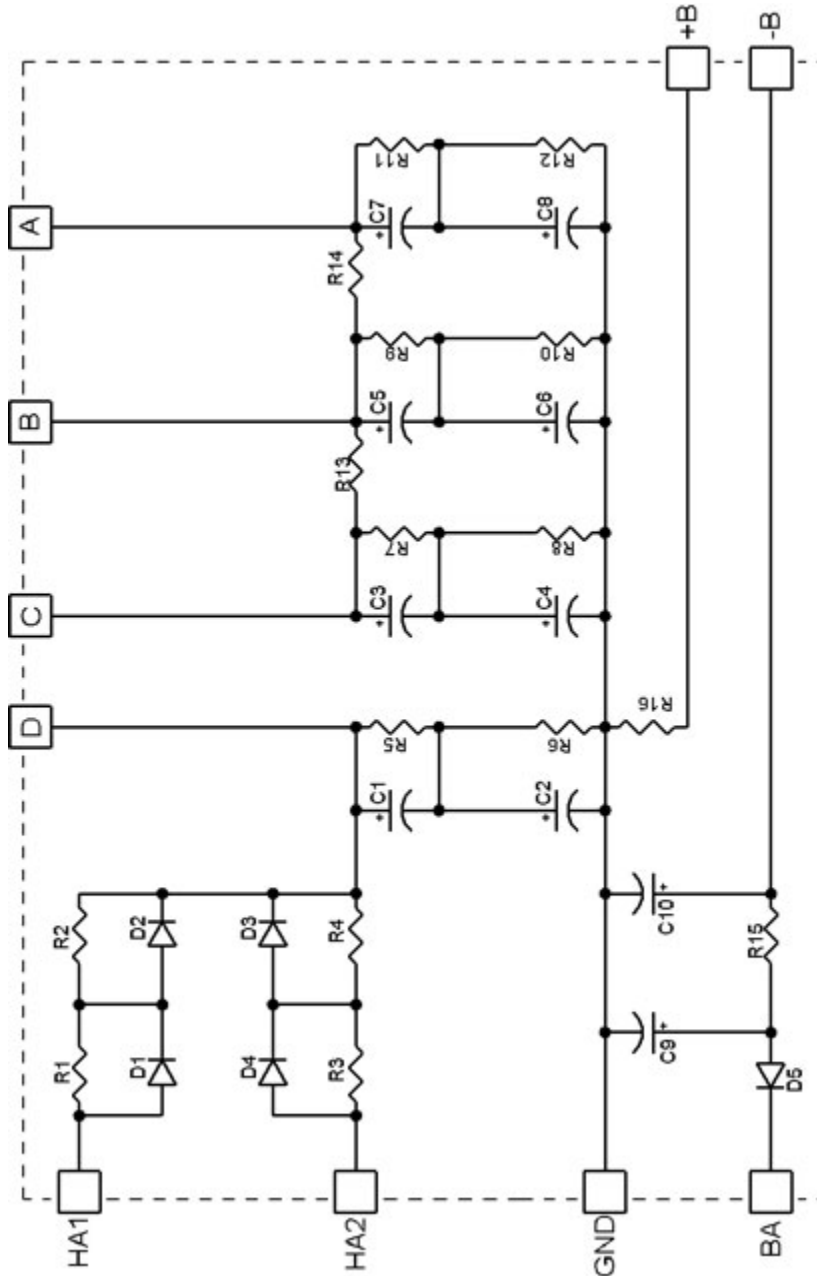

# Dynaco ST-70 & Mark 2/3 Quad-Cap / Power Supply Module Below Chassis Version Assembly, Installation & Setup Manual

## Figure 1 PC-S7U-B Component Placement Diagram

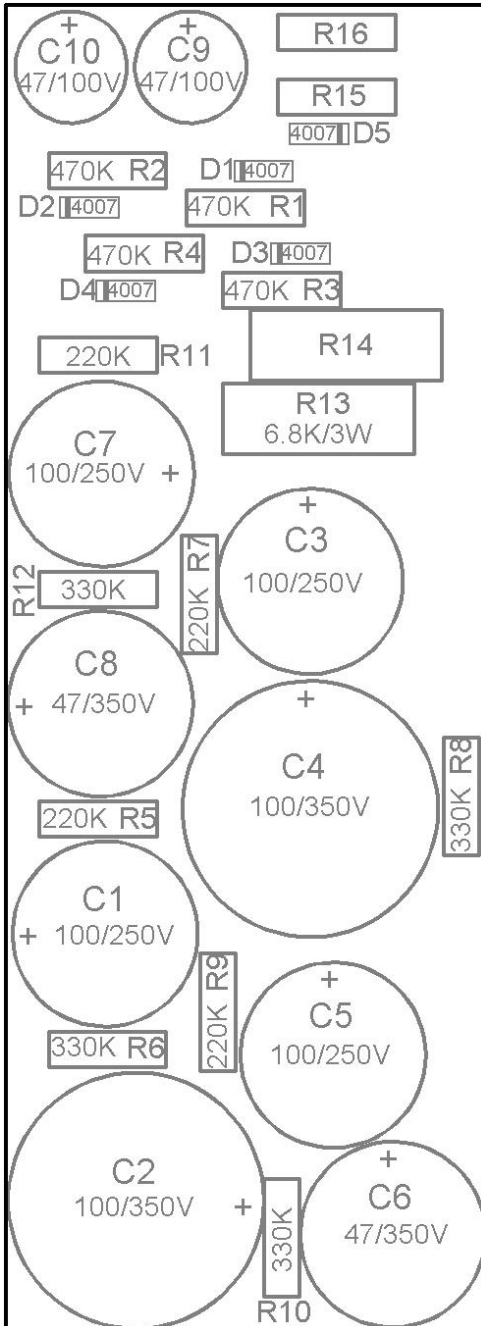

Stereo 70 Values			
	R14	R15	R16
Standard Bias	22K	10K	10K
Expanded Bias	22K	6.2K	6.2K
DC Balance-Bias	22K	4.7K	7.5K

Mark 2/3 Values			
	R14	R15	R16
Standard Bias	Omit	1K	18K
Expanded Bias	Omit	Not Available	
DC Balance-Bias	Omit	10	22K

## Figure 2A

### S7U-B Lead Connections For Stereo-70

NOTE – WHITE Wires Shown as  
VIOLET for Clarity

NOTE – Cut away mounting holes  
to edge of board to aid installation

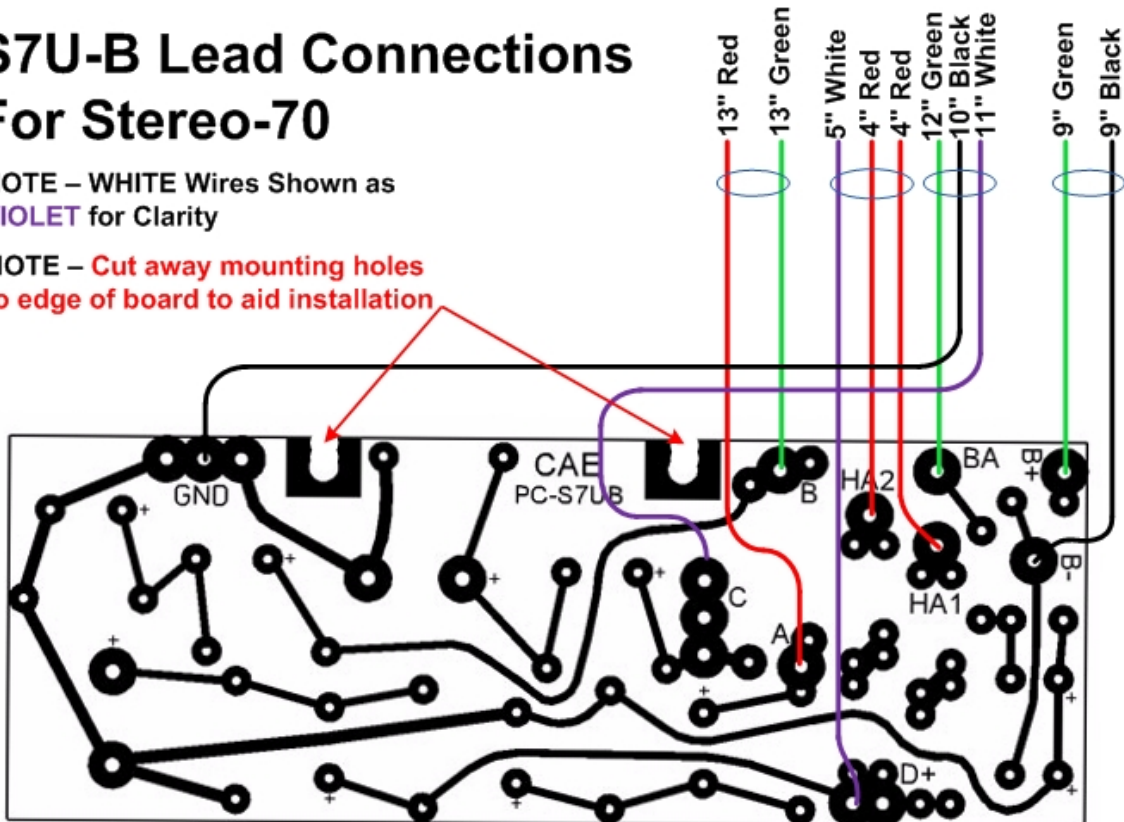



## Figure 2B

### S7U-B-M3 Lead Connections For Mark 2/3

NOTE – WHITE Wires Shown as  
VIOLET for Clarity

NOTE – Cut away mounting holes  
to edge of board to aid installation

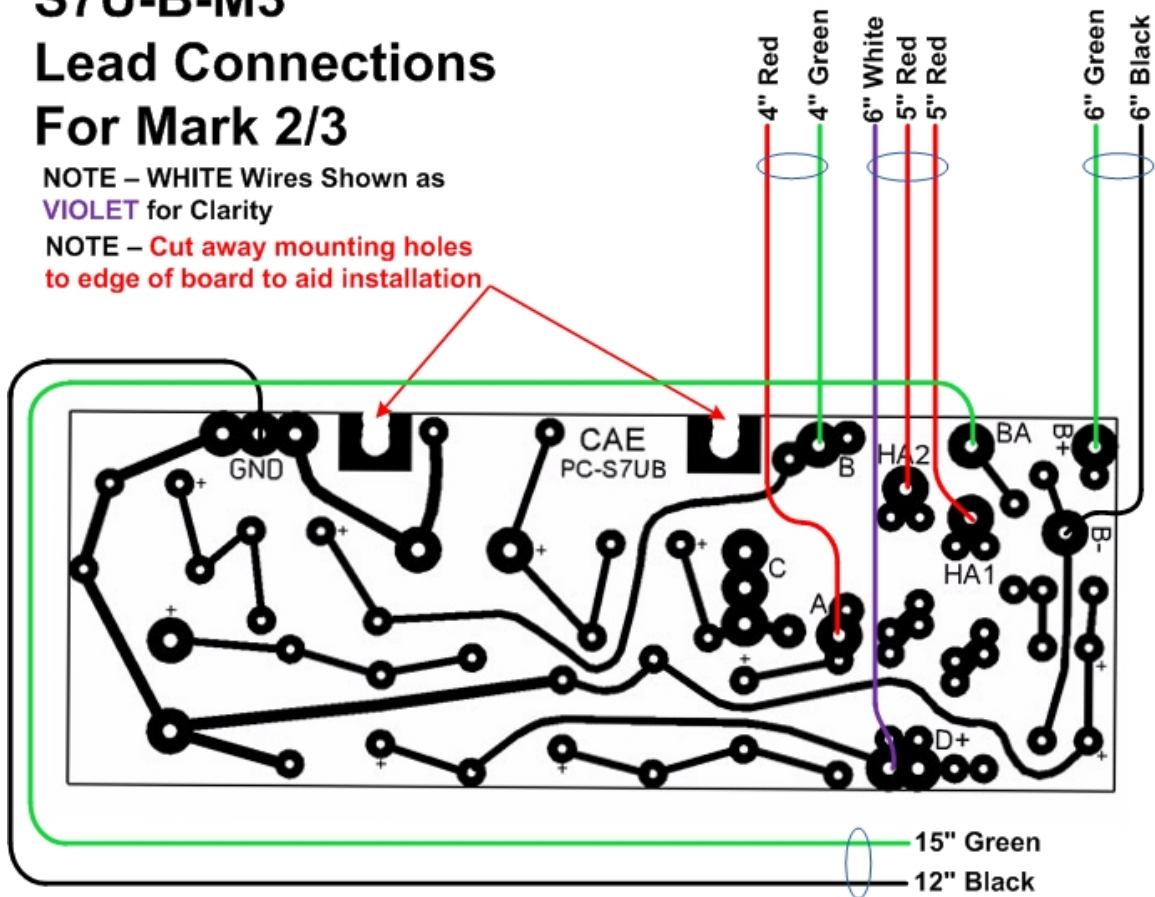

## Figure 3A – Stereo 70 Installation and Wiring Diagram

Note – In this figure ASM-7U-B Module is positioned correctly but incorrectly oriented. Correct orientation will have the module placed perpendicular to the bottom surface of the chassis. Orientation shown is to illustrate the connection and wiring of the module.

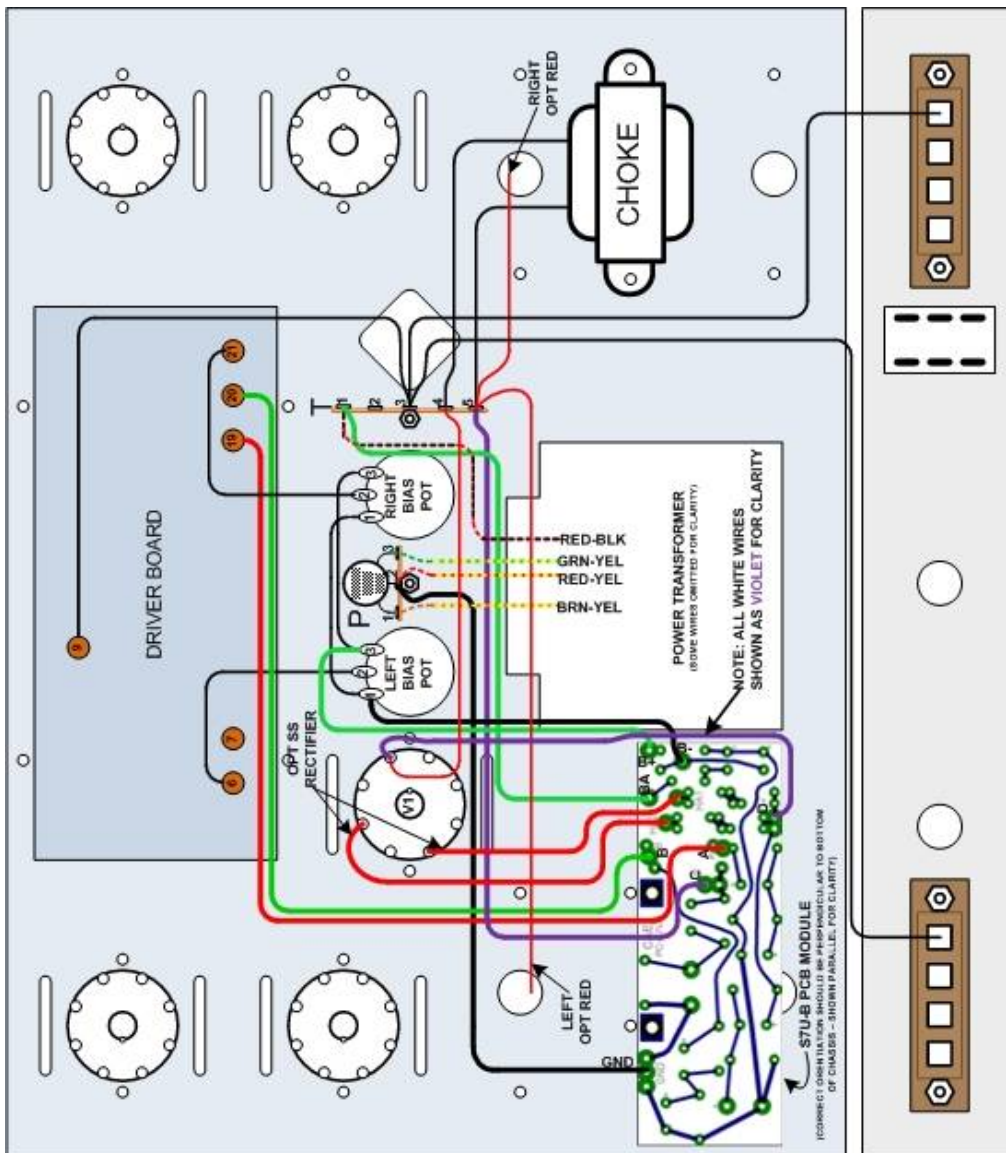

## Figure 3B – Mark 2/3 Installation and Wiring Diagram

Note – In this figure ASM-7U-B-M3 Module is positioned correctly but incorrectly oriented. Correct orientation will have the module placed perpendicular to the bottom surface of the chassis. Orientation shown is to illustrate the connection and wiring of the module.

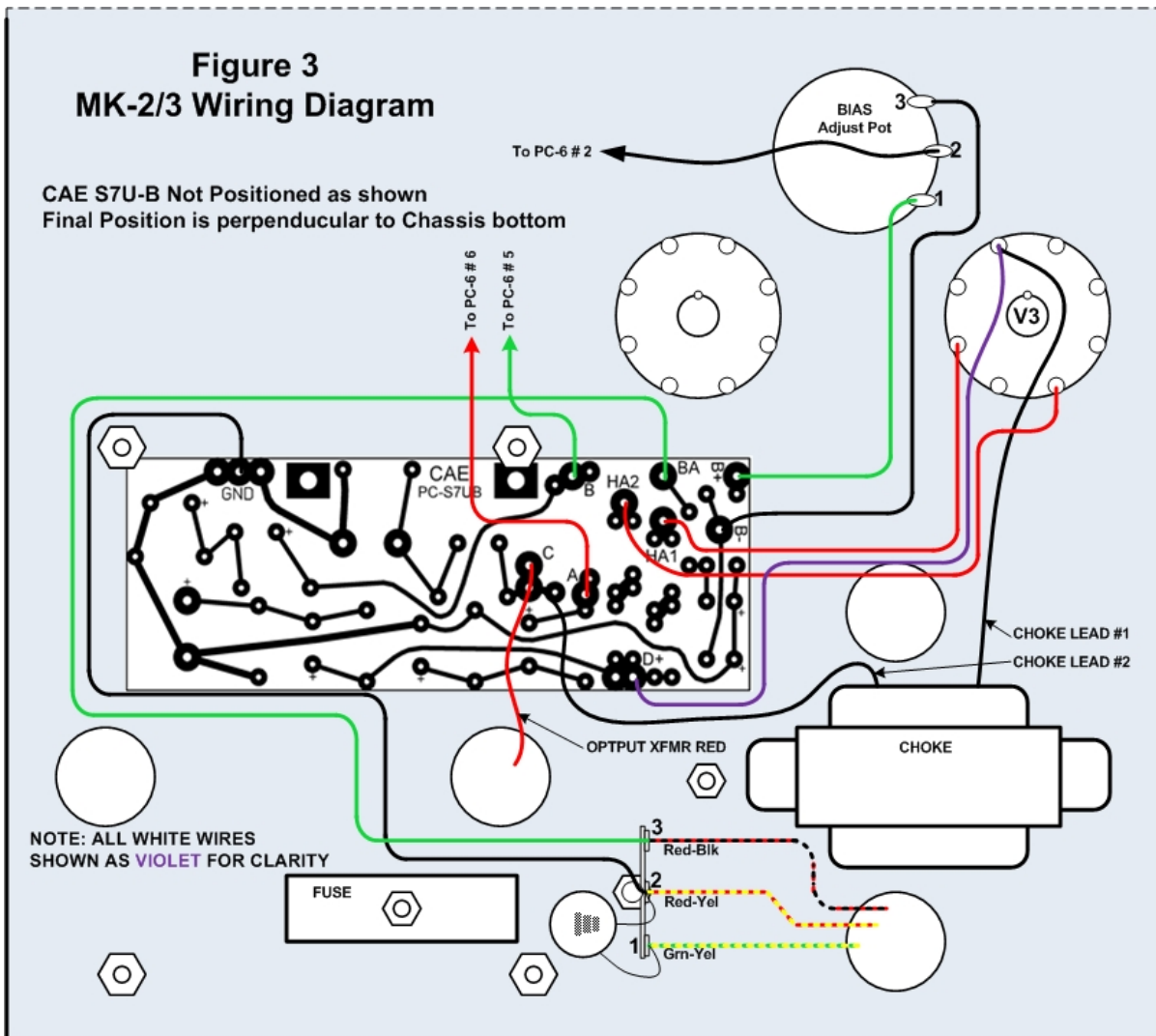

# Dynaco ST-70 & Mark 2/3 Quad-Cap / Power Supply Module Below Chassis Version Assembly, Installation & Setup Manual

## Figure 4A Stereo 70 Original Wiring Diagram

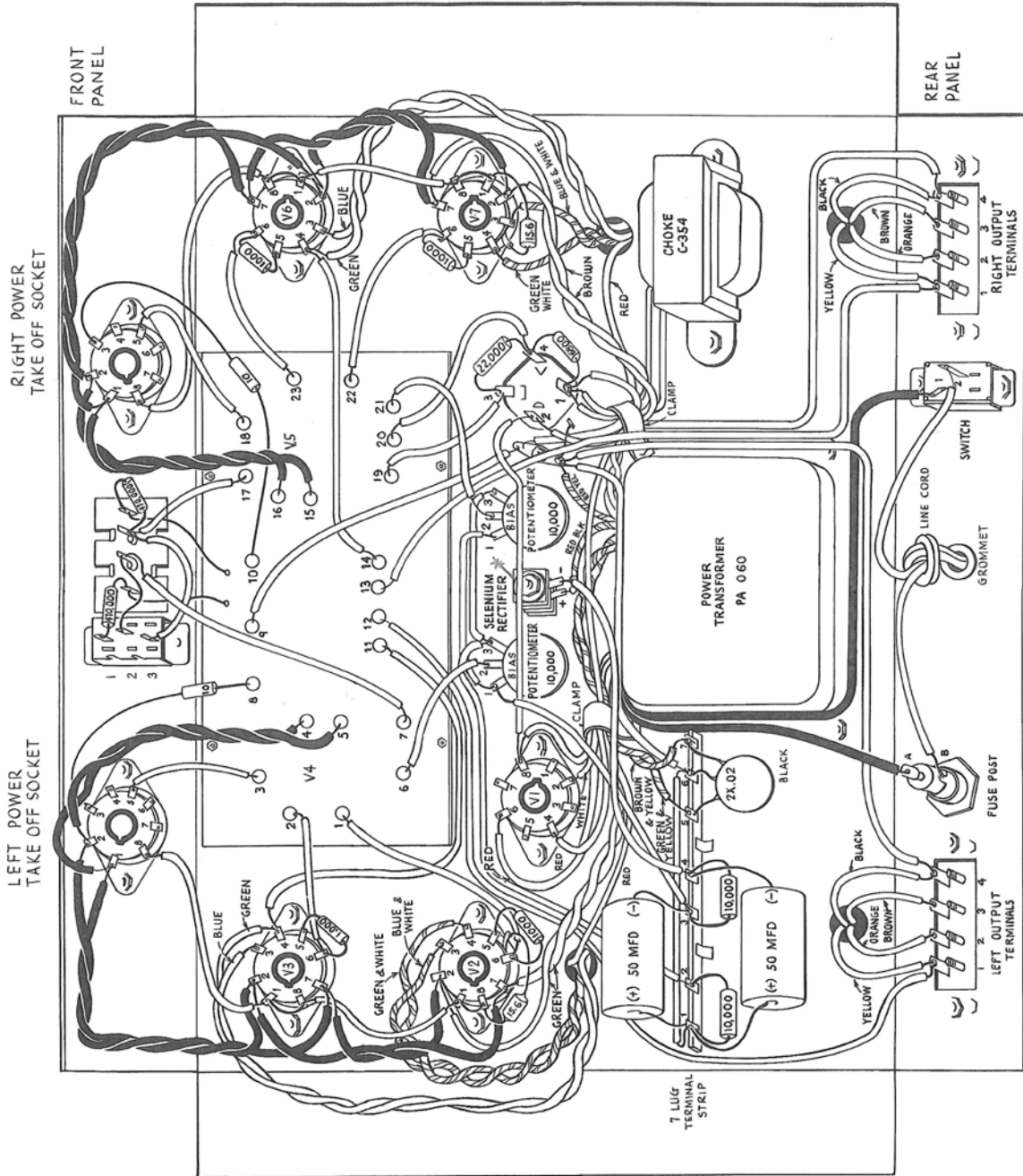

PICTORIAL DIAGRAM - DYNAKIT STEREO 70



# Dynaco ST-70 & Mark 2/3 Quad-Cap / Power Supply Module Below Chassis Version

## Assembly, Installation & Setup Manual

CAE QUAD Cap Replacement Module PC-S7U-B & PC-S7U-B-M3 Rev3, 2-11

### Figure 4B Mark 2/3 Original Wiring Diagram

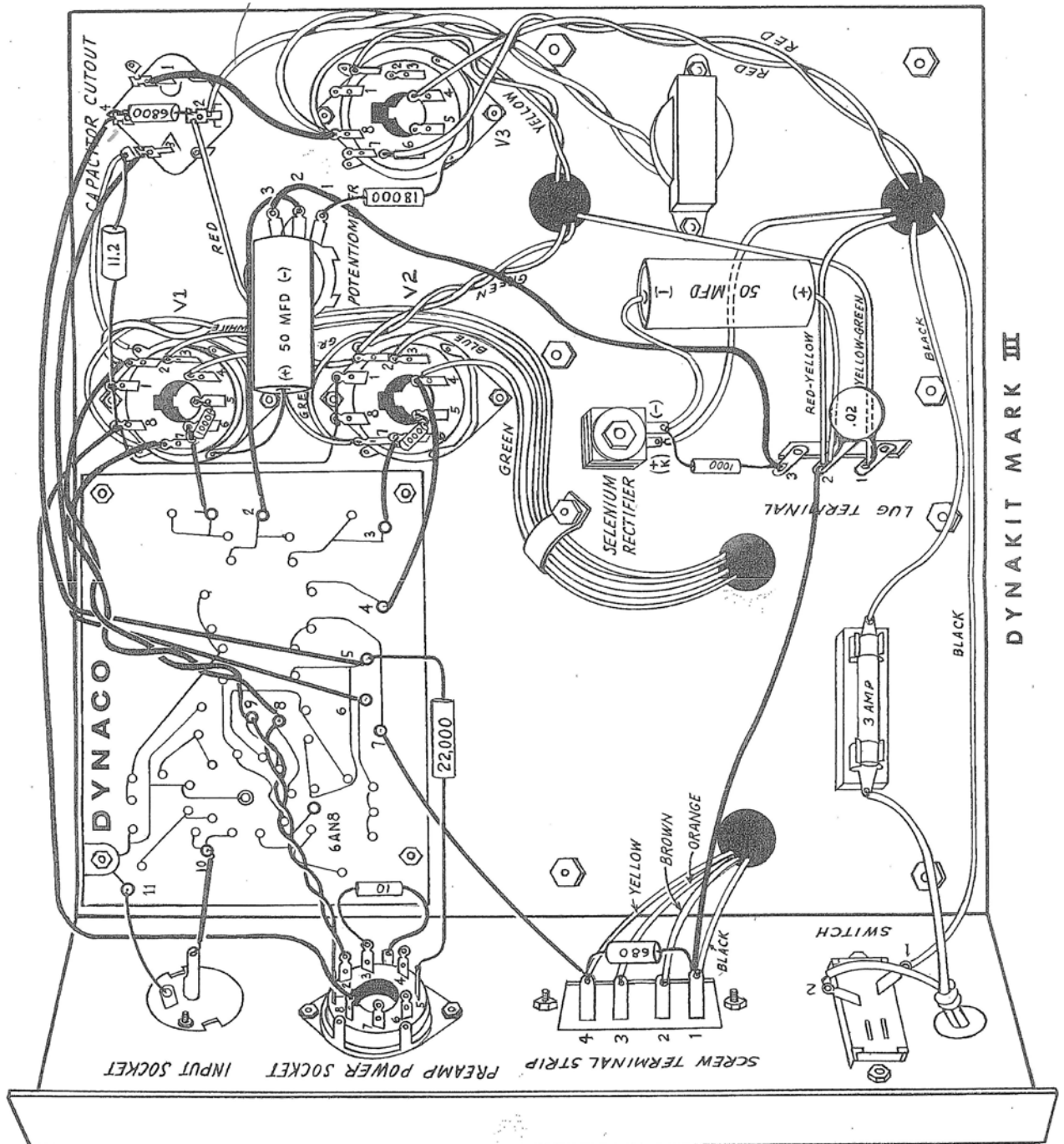



# Dynaco ST-70 & Mark 2/3 Quad-Cap / Power Supply Module Below Chassis Version Assembly, Installation & Setup Manual

CAE QUAD Cap Replacement Module PC-S7U-B & PC-S7U-B-M3 Rev3, 2-11

## CAE QUAD Cap & Bias Module

1-11 R3

**CAE# ASM-S7U-B**

**Stereo 70 QUAD Capacitor & Bias Supply Module, Below Chassis**

PAGE 1

DESIG	DESCRIPTION	QNTY	PART NUMBER	VAL / VOLT
C1, C3, C5, C7	CAPACITOR, ELECTROLYTIC (RADIAL)	4	MSR#140-XRL-250V100	100uF/250VDC
C2, C4	CAPACITOR, ELECTROLYTIC (RADIAL)	2	MSR#140-XRL-350V100	100uF/350VDC
C6, C8		2	MSR#140-XRL-350V47	47uF/350VDC
C9,C10	CAPACITOR, ELECTROLYTIC (RADIAL)	2	MSR#140-XRL-100V47	47uF/100VDC
D1 To D5 (OPT)	DIODE, POWER	5	MSR#583-1N4700	1000 V / 1A
R1,R2,R3,R4	RESISTOR, CARBON FILM	4	MSR#293-470K	470K, 1/2W
R5, R7, R9, R11	RESISTOR, CARBON FILM	4	MSR#293-220K	220K, 1/2 W
R6, R8, R10, R12	RESISTOR, CARBON FILM	4	MSR#293-330K	330K, 1/2 W
R13	RESISTOR, METAL OXIDE	1	MSR#283-6.8K	6.8K, 3W
R14	RESISTOR, METAL OXIDE	1	MSR#283-22K	22K, 3W
R15	RESISTOR, METAL OXIDE	1	MSR#281-10K	10K, 1W
R16	RESISTOR, METAL OXIDE	1	MSR#281-10K	10K, 1W
X1	PRINTED CIRCUIT BOARD	1	CAE# PC-S7U-B	
X3	3/8 ANGLE BRACKET, THREADED	2	CAE# MC-27-3910	
OPT-3PTS	TERMINAL STRIP – 3 Pin	1	CAE# 3PTS	
OPT-5PTS	TERMINAL STRIP – 5Pin	1	CAE# 5PTS	

NOTES: CAE# - Curcio Audio Part Number  
 DK# - DigiKey Part Number      MSR# - Mouser Part Number



# Dynaco ST-70 & Mark 2/3 Quad-Cap / Power Supply Module Below Chassis Version Assembly, Installation & Setup Manual

CAE QUAD Cap Replacement Module PC-S7U-B & PC-S7U-B-M3 Rev3, 2-11

## CAE QUAD Cap & Bias Module

1-11 R3

**CAE# ASM-S7U-B-M3 (Mark 2/3)**

**Mark 2/3 QUAD Capacitor & Bias Supply Module, Below Chassis**

PAGE 1

DESIG	DESCRIPTION	QNTY	PART NUMBER	VAL / VOLT
C1, C3, C5, C7	CAPACITOR, ELECTROLYTIC (RADIAL)	4+4	MSR#140-XRL-250V100	100uF/250VDC
C2, C4	CAPACITOR, ELECTROLYTIC (RADIAL)	2+2	MSR#140-XRL-350V100	100uF/350VDC
C6, C8		2+2	MSR#140-XRL-350V47	47uF/350VDC
C9,C10	CAPACITOR, ELECTROLYTIC (RADIAL)	2+2	MSR#140-XRL-100V47	47uF/100VDC
D1 To D5 (OPT)	DIODE, POWER	5+5	MSR#583-1N4700	1000 V / 1A
R1,R2,R3,R4	RESISTOR, CARBON FILM	4+4	MSR#293-470K	470K, 1/2W
R5, R7, R9, R11	RESISTOR, CARBON FILM	4+4	MSR#293-220K	220K, 1/2 W
R6, R8, R10, R12	RESISTOR, CARBON FILM	4+4	MSR#293-330K	330K, 1/2 W
R13	RESISTOR, METAL OXIDE	1+1	MSR#283-6.8K	6.8K, 3W
R14	RESISTOR, METAL OXIDE	0	OMIT	
R15	RESISTOR, METAL OXIDE	1+1	MSR#281-1K	1K, 1W
R16	RESISTOR, METAL OXIDE	1+1	MSR#281-22K	18K, 1W
X1	PRINTED CIRCUIT BOARD	1+1	CAE# PC-S7U-B	
X3	3/8 ANGLE BRACKET, THREADED	2+2	CAE# MC-27-3910	

**NOTES:**

CAE# - Curcio Audio Part Number

DK# - DigiKey Part Number

MSR# - Mouser Part Number